

PRODUCT DESCRIPTION

This Balun Panel converts E1 and E2 G.703 signals from unbalanced 75 coaxial to balanced 120 twisted pair transmissions. A bi-directional device requiring no external power, it allows the user to connect telecommunications equipment with mismatched interfaces. This product offers the following features:-

- coax to twisted pair conversion
- 75 to 120 impedances
- exceeds G.703 requirements
- mounts in standard 19" rack
- teflon coaxial insulators
- BNC(f) to Amplimite connector
- >33dB return loss 0.3 to 3MHz
- mount coax or 50 pin D to front
- gold plated connector pins
- optional designation strips
- RoHS compliant
- <0.15dB E1 insertion loss
- mount recessed to ease cable entry
- zinc sealed, powder coated steel
- .050 50way mini Telco option available

OPERATING CONDITIONS

Matching Impedance: 75 unbalanced coaxial to 120 balanced twisted pair
 Bit Rate: 2Mbit/s (E1) and 8Mbit/s (E2) per ITU-T G.703 Line Code
 Signal Level: 2.37V nominal peak voltage at the coaxial end per G.703
 Working Temperature: -30°C to 75°C

ELECTRICAL SPECIFICATIONS

Insertion Loss: <0.15dB from 51kHz to 3.072MHz (2Mbit/s, E1) and <0.20dB from 211kHz to 12.672MHz (8Mbit/s, E2) in both directions
 Return Loss: Exceeds G.703 by >13dB for 2Mbit/s and >8dB for 8Mbit/s
 Pulse Shape: Exceeds G.703 requirements for 2Mbit/s and 8Mbit/s
 Cross Talk: >65dB from 51kHz to 12.672MHz between channels (>50dB for adjacent .050 50 pin D connector contacts)
 Isolation Voltage: >250V DC

MECHANICAL SPECIFICATIONS

Coaxial Connector: BNC female to IEC 169-8
 Body: Brass, Plated Cu/Ni
 Pin: Phosphor Bronze, Plated Cu/Ni/Au
 Insulator: Teflon
 Mating Cycles: 500min
 Amplimite Connector: Contacts: Phosphor Bronze, Plated Ni/Au
 Moulding: Thermoplastic, Black
 Shield: Steel, Nickel Plated
 Panel: Steel, Zinc Sealed and Powder Coated Black
 Panel Insulators: Thermoplastic, Black

ACCESSORIES

Mounting Brackets: For 21" and 23" racks
 Cable Management Kits: For 19", 21" and 23" rack

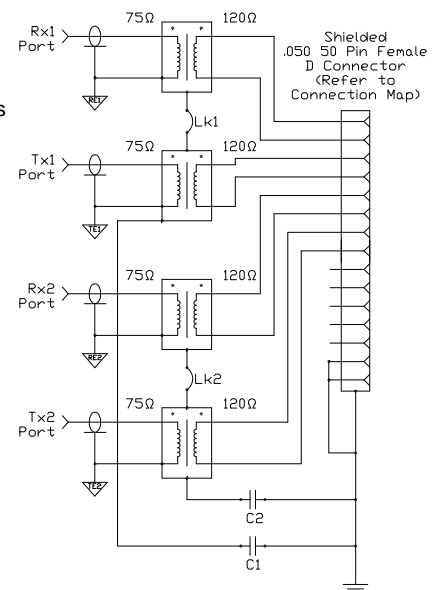

Typical Balun Pairs In Each 50 Pin D Connector