

PRODUCT DESCRIPTION

This Balun Panel converts E1 and E2 G.703 signals from unbalanced 75 coaxial to balanced 120 twisted pair transmissions. A bi-directional device requiring no external power, it allows the user to connect telecommunications equipment with mismatched interfaces. This product offers the following features:-

- coax to twisted pair conversion
- 1.0/2.3(f) to MDR68(f) (Mini Centronics)
- RoHS compliant
- 75 to 120 impedances
- >33dB return loss 0.3 to 3MHz
- <0.15dB E1 insertion loss
- mounts in standard 19" rack
- mount recessed to ease cable entry
- mount coax or MDR68 to front
- zinc sealed, powder coated steel
- gold plated contacts
- teflon coaxial insulators
- exceeds G.703 requirements
- ETSI and 23" brackets available
- optional designation strips

OPERATING CONDITIONS

Matching Impedance:	75 unbalanced coaxial to 120 balanced twisted pair
Bit Rate:	2Mbit/s (E1) and 8Mbit/s (E2) per ITU-T G.703 Line Code
Signal Level:	2.37V nominal peak voltage at the coaxial end per G.703
Working Temperature:	-30°C to 75°C

ELECTRICAL SPECIFICATIONS

Insertion Loss:	<0.15dB from 51kHz to 3.072MHz (2Mbit/s, E1) and <0.20dB from 211kHz to 12.672MHz (8Mbit/s, E2) in both directions
Return Loss:	Exceeds G.703 by >13dB for 2Mbit/s and >8dB for 8Mbit/s
Pulse Shape:	Exceeds G.703 requirements for 2Mbit/s and 8Mbit/s
Cross Talk:	>65dB from 51kHz to 12.672MHz between channels (>50dB for adjacent MDR68 connector contacts)
Isolation Voltage:	>250V DC

MECHANICAL SPECIFICATIONS

Coaxial Connector:	1.0/2.3 female to IEC 169-29 Body: Brass, Plated Cu/Ni/Au Pin: Beryllium Copper, Plated Cu/Ni/Au Insulator: Teflon Mating Cycles: 500min
MDR68 Connector (SCSI):	Contacts: Phosphor Bronze, Plated Ni/Au Moulding: Thermoplastic, Black Shell: Steel, Plated Ni Housing: Die Cast, Plated Ni
Panel:	Steel, Zinc Sealed and Powder Coated Black
Panel Insulators:	Thermoplastic, Black

ACCESSORIES

Cable Assemblies:	MDR68(m) to MDR68(m) on shielded 34 pair cable
Mounting Brackets:	For ETSI 21" and 23" racks
Cable Management Kits:	For 19", 21" and 23" racks

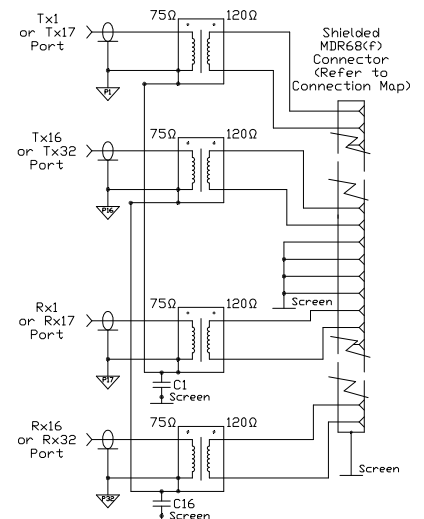

Balun Circuit For Each MDR68 (68 Way SCSI)