

PRODUCT DESCRIPTION

This Balun Panel converts 32 G.703 E1 or E2 transmissions from unbalanced 75 Ω coaxial to balanced 120 Ω twisted pair. A bi-directional device requiring no external power, it connects telecommunications equipment with mismatched interfaces or facilitates the conversion from coaxial to twisted pair distribution wiring. In addition this product offers the following features:-

- coax to twisted pair conversion
- exceeds G.703 requirements
- >33dB return loss 0.3 to 3MHz
- mounts in standard 19" rack
- shielded balun construction
- SMB(m) to IDC
- 75 Ω to 120 Ω impedances
- <0.15dB E1 insertion loss
- mount recessed to ease cable entry
- gold plated coax pins
- 2 and 8Mbit/s data rates
- RoHS compliant
- teflon coaxial insulators
- mount coax or IDC to front
- optional designation strips

OPERATING CONDITIONS

Matching Impedance: 75 Ω unbalanced coaxial to 120 Ω balanced twisted pair
 Bit Rate: 2Mbit/s (E1) and 8Mbit/s (E2) per ITU-T G.703 Line Code
 Signal Level: 2.37V nominal peak voltage at the coaxial end per G.703
 Working Temperature: -30°C to 75°C

ELECTRICAL SPECIFICATIONS

Insertion Loss: <0.15dB from 51kHz to 3.072MHz (2Mbit/s) and <0.20dB from 211kHz to 12.672MHz (8Mbit/s) in both directions
 Return Loss: Exceeds G.703 requirements by >13dB for 2Mbit/s and >8dB for 8Mbit/s
 Pulse Shape: Exceeds G.703 requirements for 2Mbit/s and 8Mbit/s
 Cross Talk: >65dB from 51kHz to 12.672MHz between channels (>50dB for adjacent module contacts)
 Isolation Voltage: >250V DC

MECHANICAL SPECIFICATIONS

Coaxial Connector: SMB male to IEC 169-10
 Body: Brass, Plated Cu/Ni/Au
 Pin: Brass, Plated Cu/Ni/Au
 Insulator: Teflon
 IDC Connector: Mating Cycles: 500min
 Wire: Conductor \varnothing 0.4 to 0.63mm
 Insulation \varnothing 0.7 to 1.1mm
 Moulding: Polycarbonate White
 Contacts: Phosphor Bronze, Tin Plated
 Mating Cycles: 50min
 Panel: Steel, Zinc Sealed and Powder Coated Black
 Panel Insulators: Thermoplastic, Black

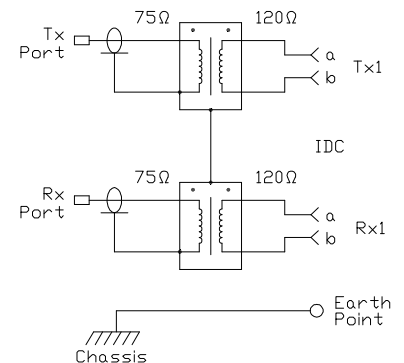

TERMINATION

IDC: Krone® Connection Tool 6089 2 003-00 or 6417 1 810-02
 registered trade mark of the Krone Company