

The E877 20dB Tap is intended for calibration, monitoring and metering in HFC networks. It's extended frequency range and housing has been optimized for broadband applications.

Up to 32 pieces of E877 may be mounted in a single 19"/21" Rack mounting panel while providing easy access. This approach creates a structured environment and occupies the smallest possible space that delivers savings to the Network.

AC&E design and manufacture a broad range of Splitters, Taps and Baluns for housing in rack mounted panels in HFC applications.



ELECTRICAL

Item	Ports	Frequency Range (MHz)	Specification (dB)
Insertion Loss	In-Out	5-40	0.8 Max
		40-470	0.9 Max
		470-862	1.0 Max
		862-1000	1.2 Max
Tap Loss	In-Tap	5-1000	18.8~21.2
Isolation	Out-Tap	5-10	36 Min
		100-40	39 Min
		40-470	37 Min
		470-862	35 Min
		862-1000	32 Min
Return Loss	Input	5-40	20 Min
		40-470	20 Min
		470-862	20 Min
		862-1000	18 Min
Return Loss	Output	5-40	20 Min
		40-470	20 Min
		470-862	20 Min
		862-1000	18 Min
Return Loss	Tap	5-40	20 Min
		40-470	20 Min
		470-862	20 Min
		862-1000	18 Min

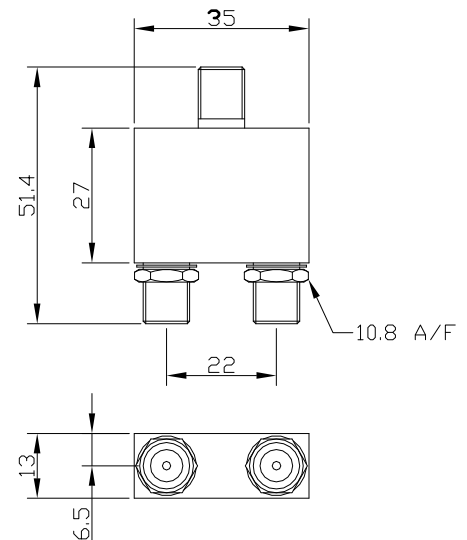

MATERIALS

Splitter Housing: Diecast. Nickel Plated
 Splitter Contacts: Phosphor Bronze. Gold Plated
 Nuts & Washers: Brass. Nickel Plated

CONNECTOR

Type: F-Type female

ENVIRONMENTAL

Working Temperature: -30°C to 75°C
 RoHS Compliance: To EU Directive 2011/65/EU

ASSOCIATED ITEMS

Panel 19" 1RU 8 Way Empty: E848
 Panel 19" 1RU 12 Way Empty: E841